

Lubricate all seals with clean hydraulic oil prior to assembly.
Do not use silicone based lubricants.

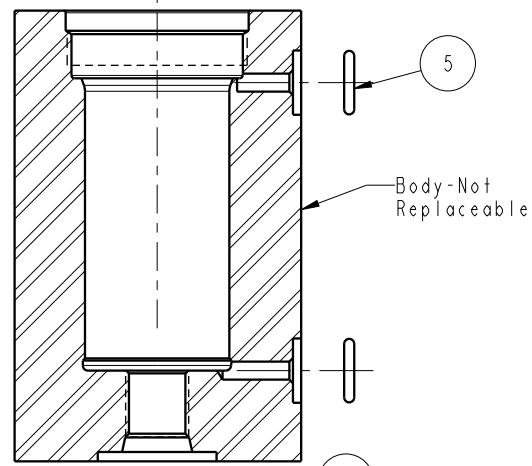
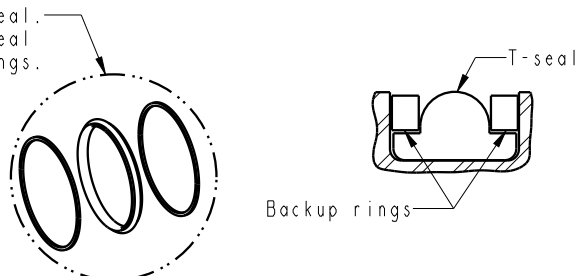
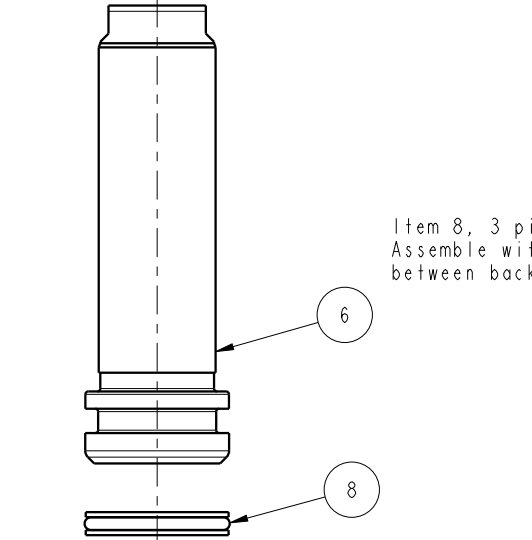
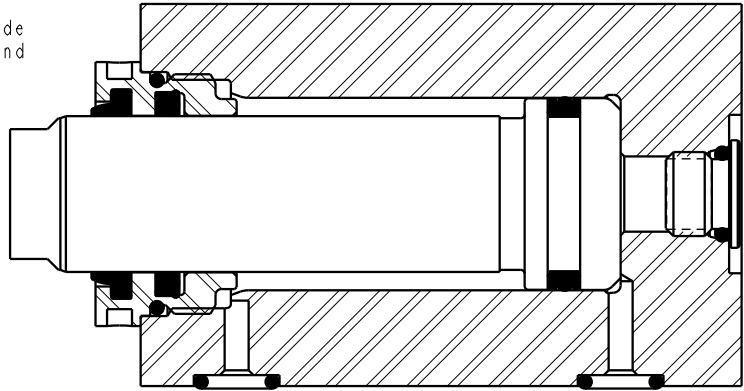
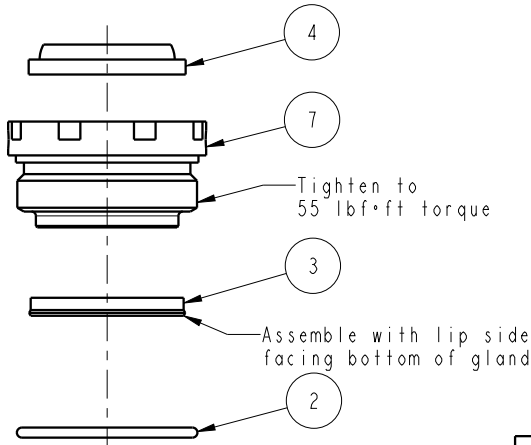

Standard Seal Kit	Fluorocarbon Seal Kit
60-2102-00	6V-2102-10
39-H100-17	39-V100-17
39-0110-45	39-0120-05
39-0010-11	39-0120-13
39-0120-08	39-0120-08
39-0500-42(2)	39-0510-25(2)

No.	QTY	PART No.	DESCRIPTION
8	1	39H10017	SEAL, T, (13/16 X 5/32 X 1)
7	1	82031002	GLAND, CYL, 3900 & 17.8 KN
6	1	82011009	PISTON, CYL, 3900, 1.5 STRK
5	2	39050042	O-RING, (-011)
4	1	39012008	WIPER, SNAP-IN, (13/16)
3	1	39011045	SEAL, LL, (13/16 X 1/8 X 1/8 X 1-1/16)
2	1	39001011	O-RING, (-024)
1	1	30601145	PLUG, SOCH, SAE 4, LOW HEAD

PARTS LIST



Model Number
21-1210-04
21-1210-04F

PARTS LIST, ASSY, CYL, BB, MM, 3900, 1.5 STRK, DA

SIZE
A

PL2162

REV
F

F	5499	RELEASE	NPETERS	9/23/24
REV	IN ACCORDANCE WITH ECN	EFFECTIVE DATE	REVISED BY	DATE
DRW BY:	JACOB	DRAWING STATUS: Released		
DATE:	4-30-97	PRODUCTION APPROVED FOR RELEASED STATUS ONLY		